

Magnum-5 Mini

A rugged 5-function subsea manipulator

ds-m5min-v1



The *Magnum-5 Mini*, from the magnum family, is a rugged 5-function manipulator used primarily in ROV applications. This manipulator is designed to be reliable while operating in harsh environments. Components and assembly make this arm completely field serviceable.

The small stow envelope makes the Magnum-5 Mini ideal for cage deployed vehicles. Typical installations have a Magnum-5 Mini port side and a Magnum-6 Mini starboard side. However, the Magnum-5 Mini is available in both port and starboard configurations.

The size and weight of this arm make it ideal for smaller vehicles that require a high lift capacity. Typical applications include jetting and brushing operations, debris clearance, valve turning and bolt torquing, cable cutting, cable repair, biological and geological sampling, archeological work, transponder and probe installation, salvage and recovery.

Principal Characteristics

Reach:	28 inches
Weight:	13 Kg (29 lbs)
Maximum Lift:	68 Kg (150 lbs)
Lift at Full Extension:	23 Kg (51 lbs)
Wrist Torque:	14 Nm (10 ft-lbs)
Grip Force:	35 Kg (78 lbs)
Operating Depth:	5000 msw (16,400 fsw)
Hydraulic Fluid:	Shell Tellus (or equivalent)
Input Pressure:	3447 kPa (500 psi)
Input Flow:	19 LPM (5 gpm)
Material:	Aluminum with stainless steel fittings
Corrosion Resistance	Black anodization and Magnesium anodes
Control:	Rate

International Submarine Engineering Ltd.

1734 Broadway Street, Port Coquitlam, BC V3C 2M8 Canada

Tel: 604.942.5223 Fax: 604.942.7577

manips@ise.bc.ca www.ise.bc.ca

Magnum-5 Mini

Operating Envelope

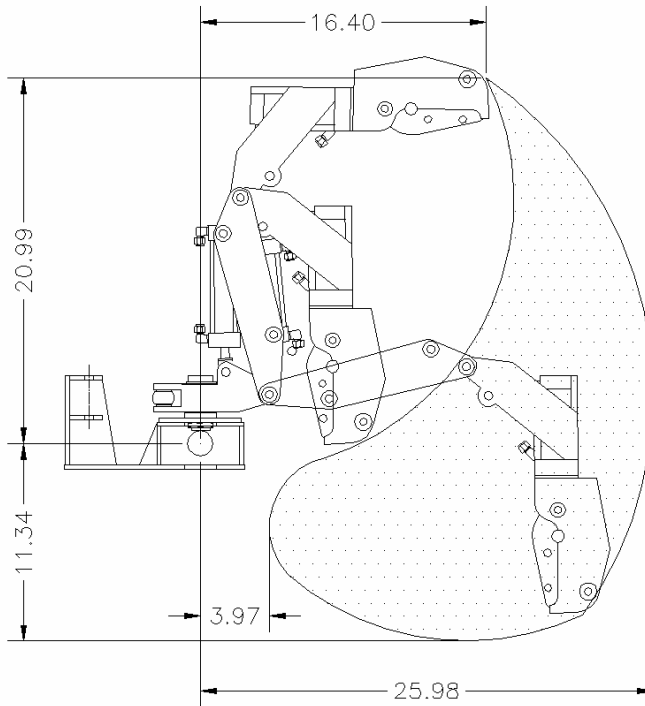

Gripper Options

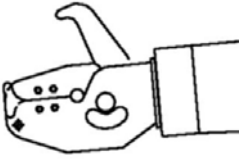
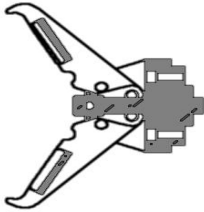
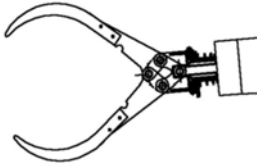
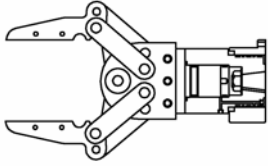
Single Sided	Scissor	Claw	Parallel
			

Controller Options

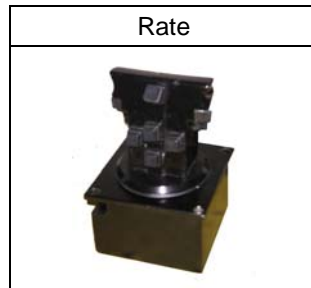

International Submarine Engineering Ltd.

1734 Broadway Street, Port Coquitlam, BC V3C 2M8 Canada

Tel: 604.942.5223 Fax: 604.942.7577

manips@ise.bc.ca www.ise.bc.ca